

Data sheet

FT80

Humidity and temperature measuring device
ECO-LINE ®

09015260 • DB_EN_FT80 • Rev. ST4-B • 04/23

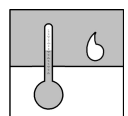

1 Product and functional description

1.1 Performance characteristics

Typical applications

- Humidity and temperature measurement
- Technical facility equipment (TGA)
- Space and clean room monitoring
- Air intake/exhaust systems
- Process monitoring

Main features

- Maintenance-free
- Simple parametrisation via DIP switch
- Humidity and temperature measurement
 - 0 to 100 % rH
Measurement error of up to 2 % rH
 - -20 to +70 °C
Measurement error of up to 0.2 °C
- Analogue output signal
 - Temperature: 0/4 ... 20 mA or 0/2 ... 10 V; 3-conductor
 - Humidity: 0/4 ... 20 mA or 0/2 ... 10 V; 3-conductor
- Optional full graphic LC display
- Optional digital RS485 Modbus RTU interface

1.2 Intended use

The FT80 is suitable for the measurement of humidity and temperature in non-condensing air.

The device may only be used for the purpose stipulated by the manufacturer. The manufacturer will not be liable for damage arising from incorrect or improper use.

1.3 Function diagram

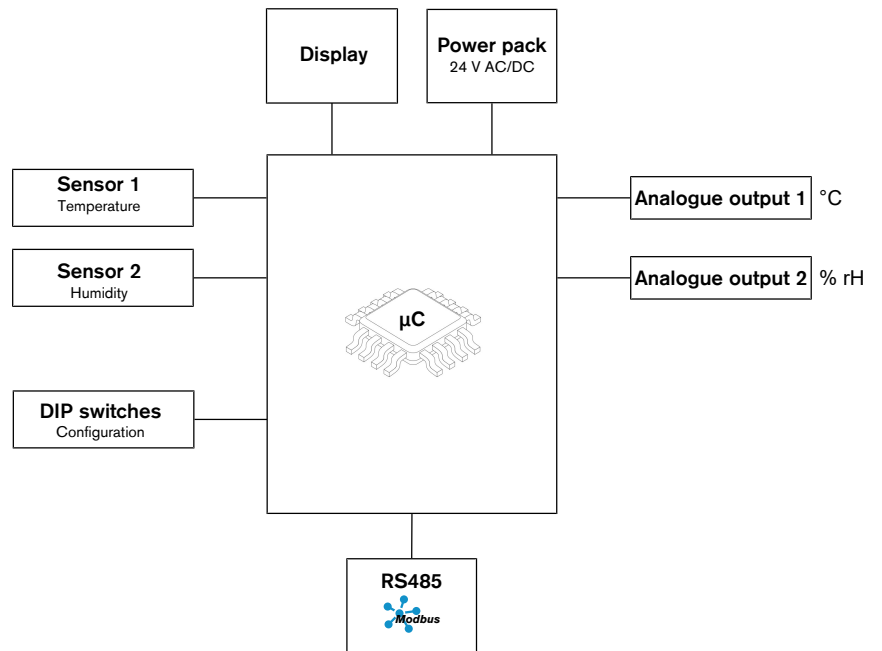

Fig. 1: Function diagram

1.4 Design and mode of operation

The temperature and humidity measurement is based on a sensor chip with a digital I2C bus interface. The analogue measurement data is digitally converted and linearised. The transmitted data is evaluated by the integrated electronics and then output via an optional display, analogue outputs or via the optional Modbus output.

1.5 Device versions

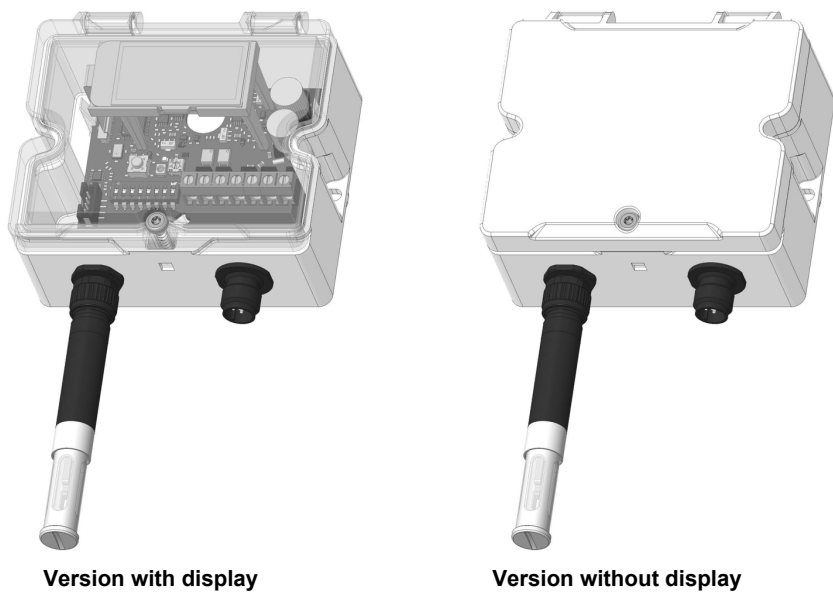

Fig. 2: Device versions

1.5.1 Process connection

NOTICE! The sensor can also be mounted remotely with an M12 cable.

Humidity and temperature measuring device
Standard

Humidity and temperature measuring device
Duct sensor

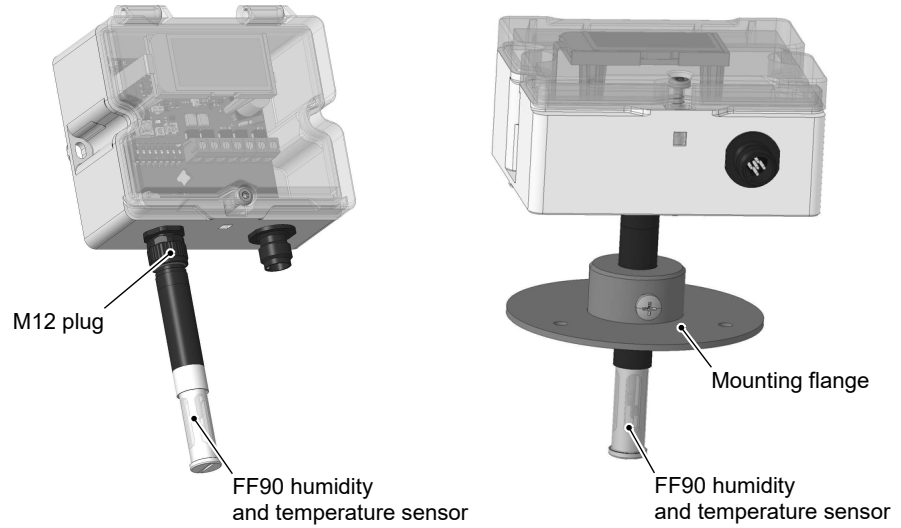

Fig. 3: Process connections

1.5.2 Electrical connection

Option A:
Cable screw connection

Option B:
M12 plug connection

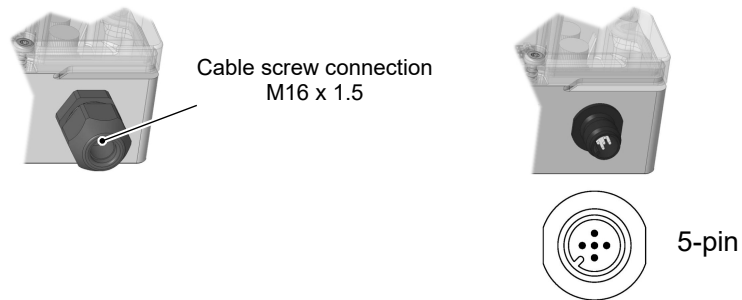

Fig. 4: Electric connections

2 Technical data

2.1 General

Type designation	FT80	
Measuring variable	Humidity	
	Temperature	
Measurement principle	Humidity	Capacitive
	Temperature	Band gap
Remote sensor	5 m max. cable length (between sensor and device)	
Installation position	Sensor with filter side in the range vertical down to horizontal	
Reference conditions (acc. to IEC 61298-1)		
Temperature	+15 to +25 °C	
Relative humidity	45 ... 75%	
Air pressure	86 to 106 kPa	860 to 1060 mbar

2.2 Input variables

	Sensor assembly	Temperature measuring range	
Basic measuring range	On device	-20 to +70 °C	
	Offset	-40 to +95 °C	
Adjustable via DIP switch		-20 to +80 °C	0 ... 200 °F
		0 to +50 °C	+40 to +140 °F
		-40 to +60 °C	-40 to +160 °F
		-15 to +35 °C	0 ... +100 °F
		Humidity measuring range	
Adjustable via DIP switch	Relative humidity	0 ... +100 % rH	
	Enthalpy	0 ... +85 kJ/kg	
	Absolute humidity	0 ... +50 g/m ³	0 ... +80 g/m ³
	Dew point	0 to +50 °C	-20 to +80 °C
		+40 to +140 °F	0 ... +200 °F

2.3 Output sizes

A DIP switch can be used to switch the analogue outputs between 0 ... 20 mA / 0 ... 10 V and 4 ... 20 mA / 2 ... 10 V (Live Zero).

Temperature analogue output, 3-conductor

Output signal 1	0 to 20 mA	0 ... 10 V
	4 to 20 mA	2 ... 10 V
Signal range	0.0 to 21.5 mA	0.0 to 10.75 V
Load impedance R_L	$\leq 600 \Omega$	$\geq 2 \text{ k}\Omega$

Humidity analogue output, 3-conductor

Output signal 2	0 to 20 mA	0 ... 10 V
	4 to 20 mA	2 ... 10 V
Signal range	0.0 to 21.5 mA	0.0 to 10.75 V
Load impedance R_L	$\leq 600 \Omega$	$\geq 2 \text{ k}\Omega$

2.4 Measuring accuracy

2.4.1 Humidity

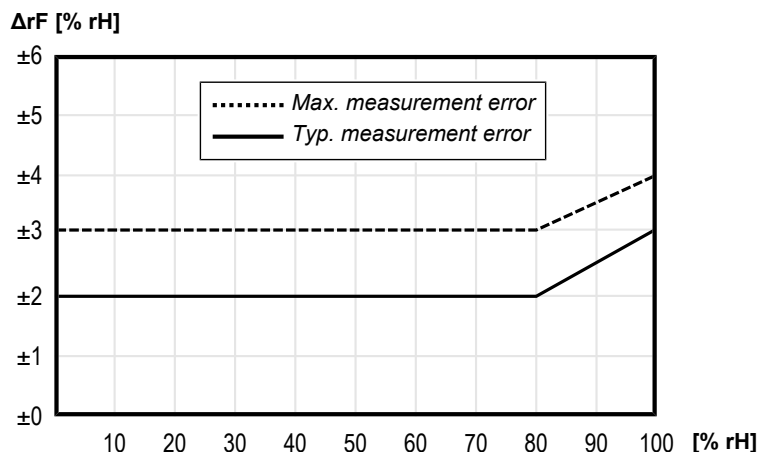

Fig. 5: Measurement error at 25 °C

Measurement deviation	± 3 % rH
Hysteresis	± 1.0 % rH
Typical repeatability	± 0.21 % rH
Long-term stability	≤ 0.25 % rH/year

If the sensor is operated continuously at a humidity of over 80 % rH, the measurement error can still exceed the specified maximum value for a while after the humidity has been quickly reduced.

2.4.2 Temperature

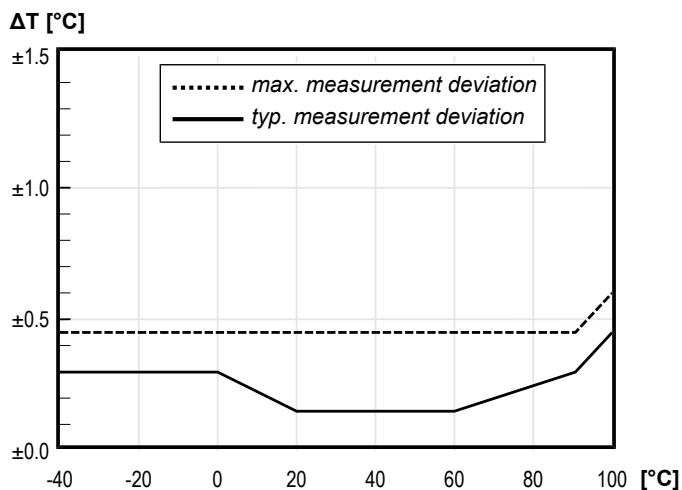

Fig. 6: Typical measurement error of temperature

Typical measurement error	± 0.3 °C
Typical repeatability	± 0.15 °C
Long-term drift	< 0.3 °C/year

2.5 Digital interfaces

Modbus RTU interface

interface	RS 485
Report	Modbus RTU
Modbus specification	Application Protocol Specification V1.1b3 (April 26, 2012)
Address	1 ... 128
Baud rate	2400 ... 115200 Baud
Parity	Even, uneven, parity
Stopbits	1...2

2.6 Auxiliary energy

Rated voltage	24 V AC/DC
Admissible operating voltage U_b	19.2 to 28.8 V AC/DC
Absorbed power	< 2W

2.7 Operating conditions

Ambient temperature range	-20 to +70 °C
Storage temperature range	-20 to +70 °C
Protection	IP54 IP65 with enclosed screw plug
EMC	EN IEC 61326-1:2021 EN IEC 61326-2-3:2021
RoHS	EN IEC 63000:2018
REACH	There are no SVHC substances in the FT80 product.
Other applied standards	DIN EN 60730-1:2021-06 (EN 60730-1:2016 + A1:2019)

2.8 Display

Display	Full graphic LC display
Resolution	128 x 64 Pixel
Back lighting	None
Meas. data display	Display format depends on the measuring range

2.9 Construction design

Electrical connection	3-conductor	Modbus RTU
Cable screw connection	PCB terminal	PCB terminal
M16x1.5	No. of pins 5	No. of pins 5
M12 plug connection	5-pin male	5-pin male
Temperature/ Humidity sensor	4-pin female	4-pin female
Installation position	Vertical down to horizontal	
Dimensions (without connections and sensor)	92 x 45 x 83 mm	
Weight	Max. 200 g	

2.9.1 Materials

Casing	Polycarbonate PC
Temperature sensor	FR4, polycarbonate PC, solder resist, silicon, tin, copper, nickel, silver, ceramic, PBT (20% GF)

2.9.2 Dimension drawings

All dimensions in mm unless otherwise stated

Model with cable screw connection

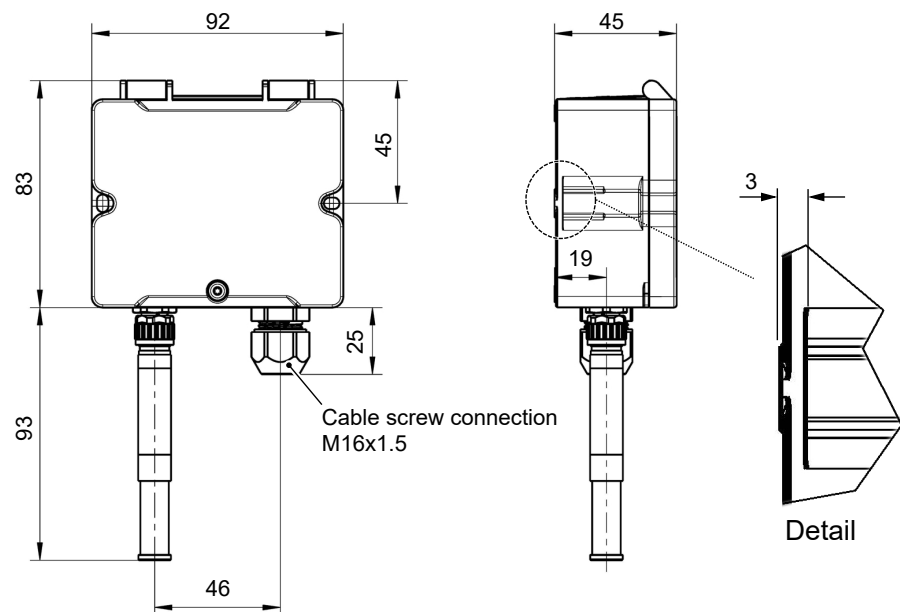

Design with M12 plug connection

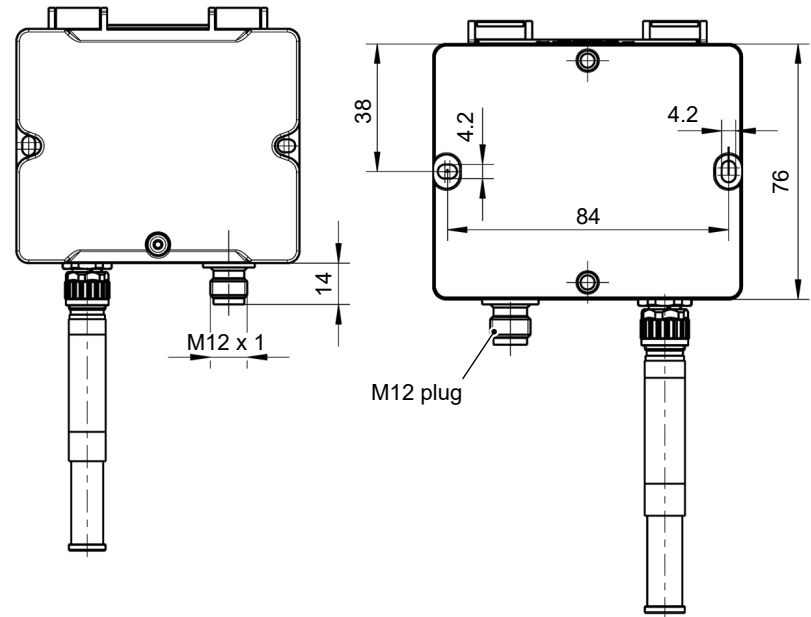

Remote sensor

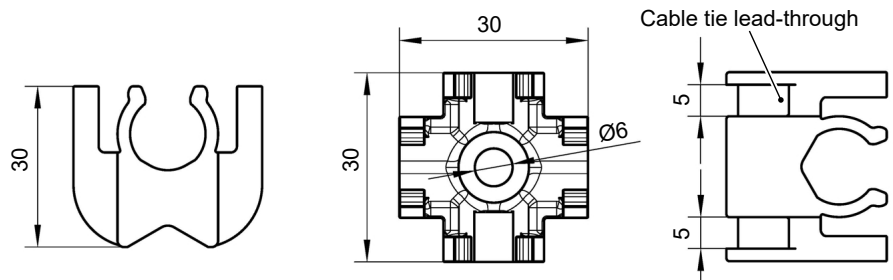

Fig. 7: Mounting clip

Duct sensor

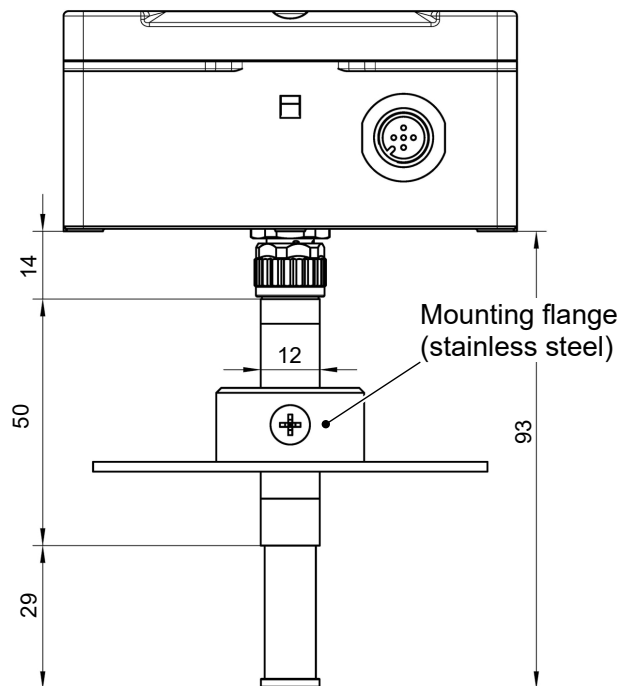

Fig. 8: Duct sensor (standard)

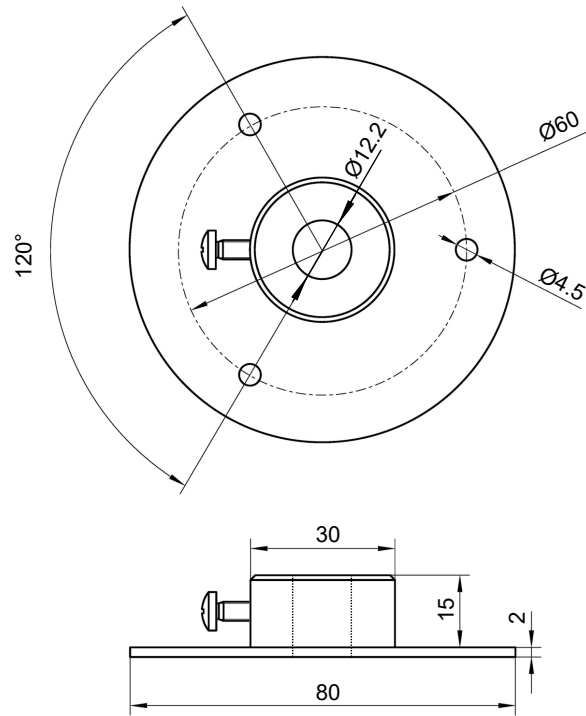

Fig. 9: Stainless steel mounting flange (12.2 mm)

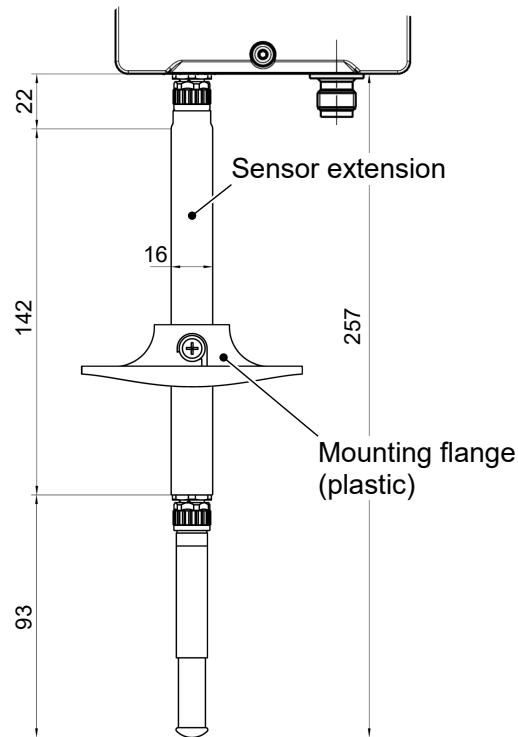

Fig. 10: Sensor extension

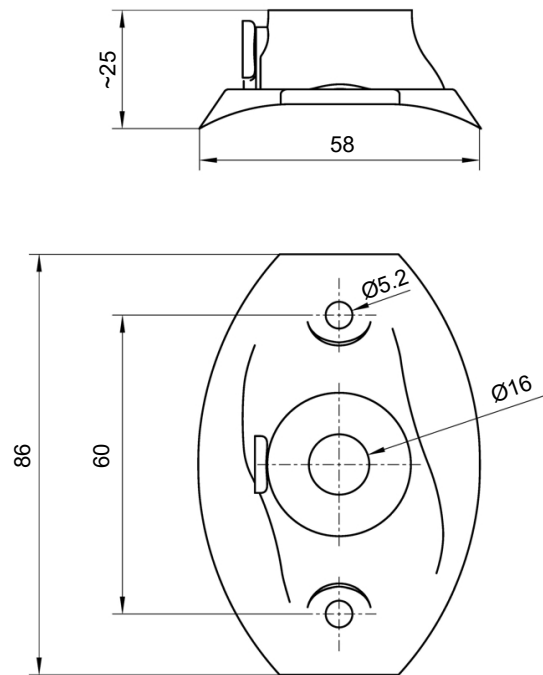
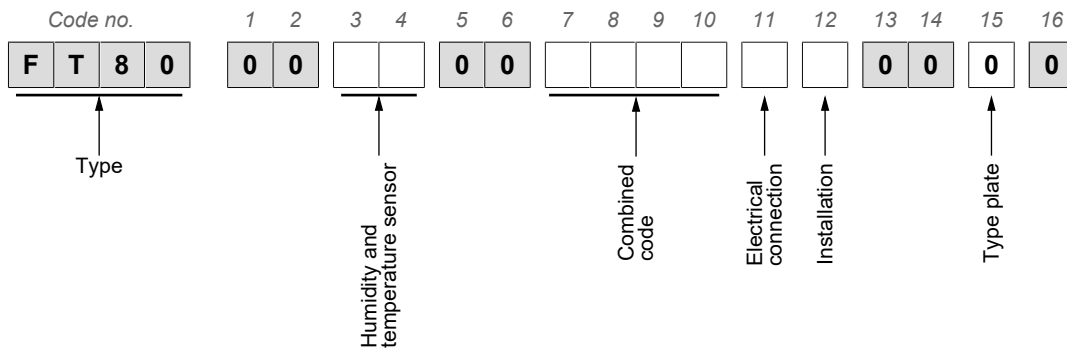

Fig. 11: Plastic mounting flange (16 mm)

3 Order codes



Measurement range:

[3.4]	Measuring range	Sensor
10	Humidity 0...100 % rH Temperature -20 ... +70 °C remote sensor -40 ... +95 °C	Plastic with stainless steel filter
40	Humidity 0...100 % rH Temperature -20 ... +70 °C remote sensor -40 ... +95 °C	Plastic with PTFE filter

Combined code

[7-10]		
AL00	Output signal Operating voltage Measured value display	0/4...20 mA, 0/2...10 V, 3-conductor 24 V AC/DC without
AL0C	Output signal Operating voltage Measured value display	0/4...20 mA, 0/2...10 V, 3-conductor 24 V AC/DC Full graphic LC display
ML00	Output signal Operating voltage Measured value display	Modbus RTU, RS485, 3-conductor 24 V AC/DC without
ML0C	Output signal Operating voltage Measured value display	Modbus RTU, RS485, 3-conductor 24 V AC/DC Full graphic LC display

Electrical connection

[11]	
E	Cable screw connection
M	M12 plug connection

Installation

[12]	
K	Duct sensor
D	Assembly of the mounting rails (also enclosed)
S	Assembly of the mounting rails (pre-mounted)
W	Wall mounting

Type plate

[15]	
0	With Fischer logo

3.1 Accessories

- **M12 connection cables**

Call sign	No. of pins	Length	Order no.
PUR connection cable with M12 coupling, A-coded (Modbus)	5-pin	2m	06401995
		5 m	06401996
		10 m	06401573

- **Connection cables for FF80 humidity and temperature sensor**

Call sign	No. of pins	Length	Order no.
M12 coupling/M12 straight connector, A-coded	4 pins	2m	09011363
		5 m	09011364

- **Modbus**

Call sign	Order no.
T-distributor unshielded	04451213
Y-distributor shielded	04451217
Field attachable connector (M12 coupling)	04459067
Field attachable connector (M12 plug)	04459065
Modbus termination resistor 120 Ohm (M12 socket)	06411280
Modbus termination resistor 120 Ohm (M12 plug)	06411279

- **Spare and assembly parts**

Call sign	Order no.
Smooth sensor made from plastic	FF80 FK
Smooth sensor made of plastic with PTFE filter	FF80 FE
Sensor extension	06405232
Mounting clip for remote sensor	09004662
Mounting flange Ø16 mm (plastic)	06051065
Mounting flange Ø12.2 mm (stainless steel 1.4571)	06402713
Screw plug (casing)	01001758

3.2 Information about the document

This document contains all technical data about the device. Great care was taken when compiling the texts and illustrations. nevertheless, errors cannot be ruled out.

Subject to technical amendments.

Notes

Notes



Hassellunden 11A, 2765 Smørum
Tel. 45 95 04 10
info@buhl-bonsoe.dk
www.buhl-bonsoe.dk



FISCHER Mess- und Regeltechnik GmbH

Bielefelder Str. 37a
D-32107 Bad Salzuflen

Tel. +49 5222 974-0
Fax +49 5222 7170
www.fischermesstechnik.de
info@fischermesstechnik.de